

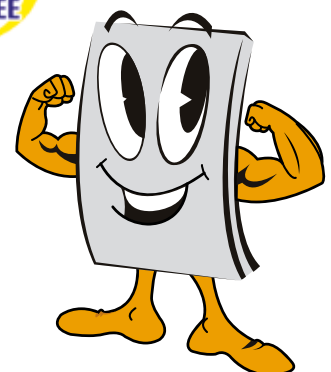

# GRC board

**THE FINEST CHOICE IN FIBRE CEMENT BOARD**



Manufactured by:  
**PT Bangunperkasa Adhitamasentra**

[www.grcboard.com](http://www.grcboard.com)



# COMPANY PROFILE

**Bangunperkasa Adhitamasentra is a fiber cement board manufacturer in Indonesia with the brand “GRC board”**

The first plant was located in Citeureup, west Java, this plant was established since 1992 and have started the production in 1994, and because of the increasing of customer’s satisfaction to GRC board products, we established the second plant in 2010, which was located at Karawang and the third plantat Jombang East Java which started operating in 2020 to meet the demand of the market. The technology that is applied is from Japan, and our product quality is of International standard.

Other than replacing the function of plywood and gypsum board, GRC board product makes beautiful the building and requires minimum maintenance. The advantages of GRC board is strong and durable, fire resistance, termites and fungi resistant, sound insulation, water resistant and smooth surface and easy to paint.

GRC board is very suitable for any kind of application such as: ceiling, partition, underlay roof, cubical toilet, cladding, façade, flooring and decorative wall. GRC board product offers the best quality, strength that is required, easy to apply, and economical.

Our factory is supported by independent R&D Department that focus on process and product development. Learning from our experiences in more than two decades, we manufactured and adjust our product to fulfill the demand and the developments of the market, and always put quality and customer service is our top priority.

# TABEL of CONTENTS

## BOARD SERIES 6-11

### GRC BOARD

- I. ADVANTAGES**
- II. PRODUCT INFORMATION**
  - A. The Function GRC board
  - B. Size and Application
  - C. Edge Profile
  - D. How to handle
  - E. Finishing
  - F. Cutting
  - G. Framing
  - H. Nails and Screws
- III. CEILING APPLICATION**
  - A. Framing Option
  - B. Frame Distance and Board Installation
  - C. Jointing Ceiling Application
- IV. PARTITION APPLICATION**
  - A. Modul Type and Partition Frame
  - B. Partition Finishing
- V. FLUSH JOINT SYSTEM ON INTERNAL APPLICATION**
  - A. Term and Condition That Have to be Noticed Before Jointing
  - B. How to do Flush Joint
  - C. Expansion Joint

## CLADDING SERIES 12-13

### GRC SUPERPANEL

- I. ADVANTAGES**
- II. PRODUCT INFORMATION**
  - A. Function
  - B. Size and Application
  - C. Cutting
  - D. Nails and Screws

### III. CONSTRUCTION AND DETAIL OF APPLICATION

- A. Frameworks
- B. Screws Position
- C. Joint
- D. Finishing

## PLANK & PLINT SERIES 14-17

### GRC SUPERPLANK, GRC SIMPLEPLANK & GRC TIMBERPLANK AND GRC MAHONI PLANK

- I. ADVANTAGES**
- II. PRODUCT INFORMATION**
  - A. Function
  - B. Size and Application
  - C. Cutting
  - D. Nails and Screws
- III. CONSTRUCTION AND DETAIL OF APPLICATION**
  - A. Plank
    - 1. Frames
    - 2. Screws Position
    - 3. Joint
    - 4. Finishing
  - B. Siding Plank
    - 1. Frames
    - 2. Screws Position
    - 3. Jointing
    - 4. Finishing
  - C. Plint
    - 1. Screw position
    - 2. Jointing
    - 3. Finishing

## FLOOR SERIES 18-19

### GRC SUPERPANEL

- I. **ADVANTAGES**
- II. **PRODUCT INFORMATION**
  - A. Function
  - B. Size and Application
  - C. Cutting
  - D. Nails and Screws
- III. **CONSTRUCTION AND DETAIL OF APPLICATION**
  - A. Frames
  - B. Screws Position
  - C. Jointing
  - D. Finishing

## DECORATIVE SERIES 22-25

- I. **ADVANTAGES**
- II. **PRODUCT INFORMATION**
  - A. Function
  - B. Size and Application
  - C. Cutting
  - D. Nails and Screws
- III. **CONSTRUCTION AND DETAIL OF APPLICATION**
  - A. Frames
  - B. Screws Position
  - C. Jointing
  - D. Finishing

### PRODUCT TECHNICAL DATA FORM

## DECK SERIES 20-21

### GRC MAHONI DECK & GRC SUPER DECK

- I. **ADVANTAGES**
- II. **PRODUCT INFORMATION**
  - A. Function
  - B. Size and Application
  - C. Cutting
  - D. Nails and Screws
- III. **CONSTRUCTION AND DETAIL OF APPLICATION**
  - A. Frames
  - B. Screws Position
  - C. Jointing
  - D. Finishing

## ACCESSORIES SERIES 26

- A. GRC Nails
- B. GRC Screws
  - i. GRC Screw for 4 mm
  - ii. GRC Screw for  $\geq 5 - 8$  mm
  - iii. GRC Screw for 9 – 15 mm
  - iv. GRC Screw for  $> 15 - 20$  mm
- C. GRC A + B Compound
- D. GRC Tape
- E. GRC PUTTY



GRC board is Fiber reinforced cement board which is safe for health

## GRC BOARD

### I. ADVANTAGES

- GRC board is Fiber reinforced cement board which is safe for health (free asbestos), that give the board characteristics of light, resistant to humidity and strong.
- It is also resistant to fungus and termites makes the building good in quality and ensures that building would be durable and easy to maintain.
- The board has smooth surface that it could be directly without having to polished the board first.
- Easy to handle and apply, which save time on installation
- GRC board has passed the following test:
  - a. ISO 9001:2015 for design/ development and

- manufacture of non asbestos fiber cement board
- b. Fire Resistant, based on the result of the test SNI 1741-2008, September 2015
- c. Sound Insulation, ISO 140: Puslitbangkim
- d. Free asbestos, base on SNI 9288 as flat cement board non asbestos
- e. Gold Certificate from Green Product Council Indonesia

### II. PRODUCT INFORMATION

#### A. The Function of GRC board

GRC board product could be applies as internal application (protected from the weather) such as wall partition application and ceiling. GRC board usually is applied on office buildings, factories, hotels, school, real estates, apartments, hospitals and etc.

## B. Size and Application

T x W x L (mm)	Weight (Kg)	Application
4 x 600 x 1200	4.7	
4 x 1220 x 2440	19,6	Ceiling
5 x 1220 x 2440/3000	25/30.7	
6 x 1220 x 2440/3000	30.1/37	Ceiling & Partition
8 x 1220 x 2440/3000	40.4/49.6	
10 x 1220 x 2440/3000	52.1/64	Partition

## C. Edge Profile

GRC board is provide two types of edge profile, Square Edge(SE) and Recessed Edge (RE)

- GRC board Square Edge (SE) is installed on the open join system

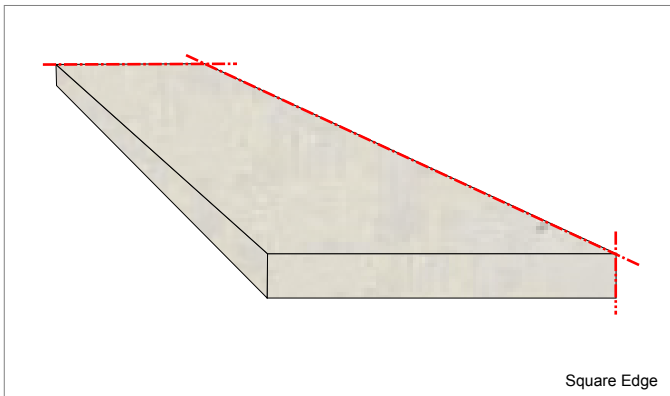

- GRC board Recessed Edge (RE) is installed on the application which requires flush joint system because it give smooth finish.

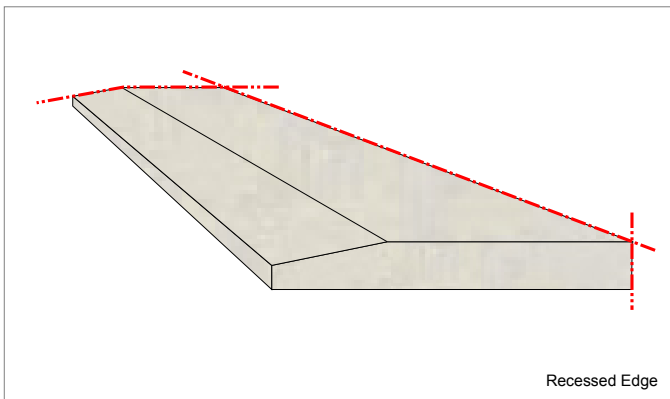

## D. How to Handle

GRC board product have to be stored in closed and dry area (not humid). For open storage we recommend to cover the product with plastic or tarpaulin to avoid the weather.



Please notice about how to handle and lift GRC board correctly, to prevent the risk of damage an the board.

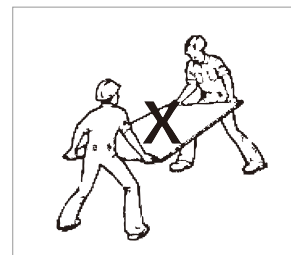
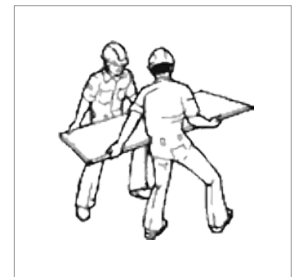
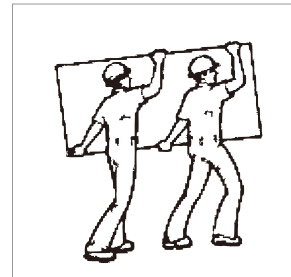

## E. Finishing

The Surface of GRC board could be painted directly by paint (all kind of paints) without polish it first. For bathroom or kitchen wall application GRC board could be covered by tiles using tile adhesive. For bathroom wall application or area which has high humidity, it is recommended to cover the GRC board with waterproofing before it would be installed to stabilize the board.

## F. Cutting

- GRC board which has thickness 4 mm, 5 mm and 6 mm could be cut by cutter or saw. For board which has thickness 8 mm and 10 mm could be cut using circular saw or chainsaw.
- For Smoothing the edge of the board that was cut, we recommend to use grinder or sandpaper.

## G. Framing

- GRC board could be applied on wood frame sized 40/60 mm or 50/70 mm, it is recommended to apply dried timber to avoid shrinkage.
- GRC board could also be applied on metal frame such as: galvanized steel, metal furring, stud steel and another type of metal frame which has thickness 0.35 mm – 1.2 mm.
- The right method of frame installation is crucial in supporting the result of GRC board application.

## H. Distance of Nails and Screws

- The minimum distance between nails or screws with the corner of GRC board is +/- 50 mm.
- The minimum distance between nails or screws with the edge of GRC board is min 12 mm.
- The Maximum distance between nails and screws is not more than 200 mm (on the side of board) and not more than 300 mm (on the middle of the board).
- The Application of nails or screws on the joint is recommended to be applied in a crisscross manner.

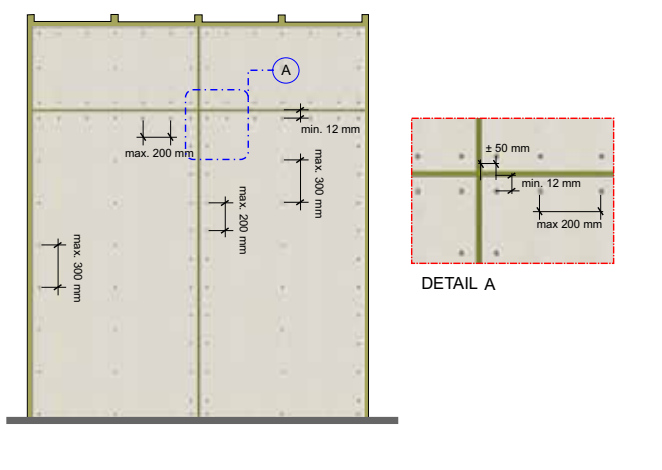

## I. Nails and Screws

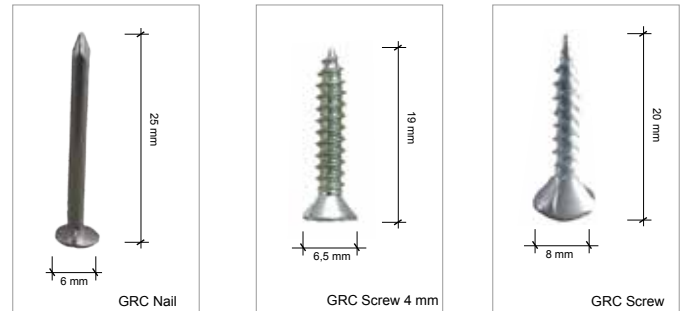

### A. Nails

For GRC board application which is sustained by wood framework could apply GRC nail. This nail has better strength than a common nail, so it is very suitable for GRC board application.

### B. Screws

For GRC board application which is sustained by metal framework could apply GRC Screw for 4 mm and GRC Screw for  $\geq 5 - 10$  mm. This Screw has a head equipped with fins and double thread. So it's easier to be countersunk, when it's applied.

## III. CEILING APPLICATION

GRC board could be applied on all kind of ceiling and also on kind of frame, and all type of joint, open joint or flush joint system.

### A. Type of frames

- Wood frames 40/60 mm or 50/70 mm.
- Hollow combination 40/40 mm and 20/40 mm which has minimum thickness 0,35 mm (full)

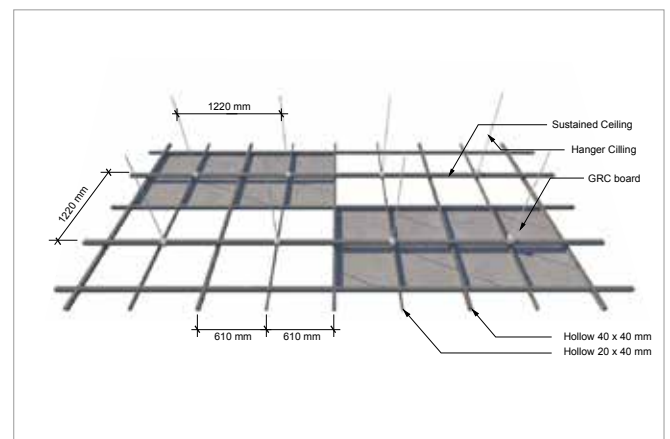



3. GRC Cross Furring system (minimum thickness 0.35 mm).

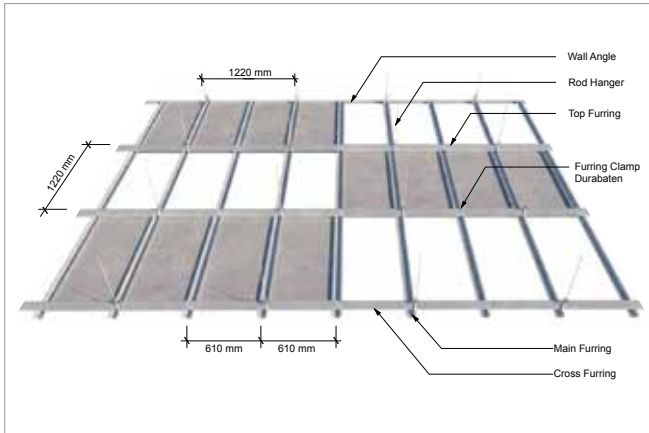

2. GRC board for Ceiling application is recommended to installed not parallel.



4. Main tee Cross Frame, for ceiling lay in application. For this application, the board that is usually applied GRC board which has the dimension 6x600x1200 mm and 6x600x600 mm without drills

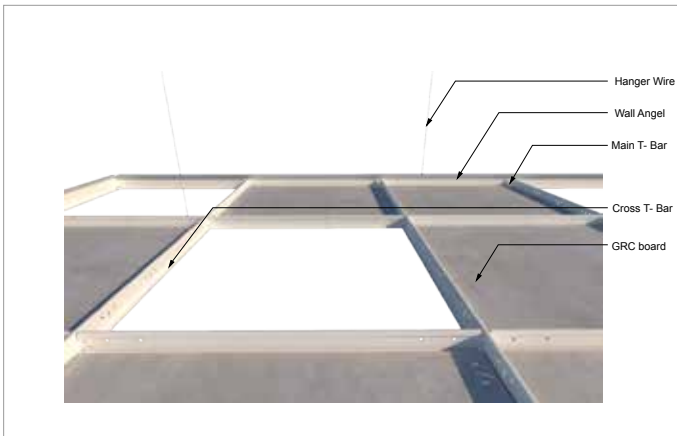

### C. Ceiling Application System

1. Open Joint Application.

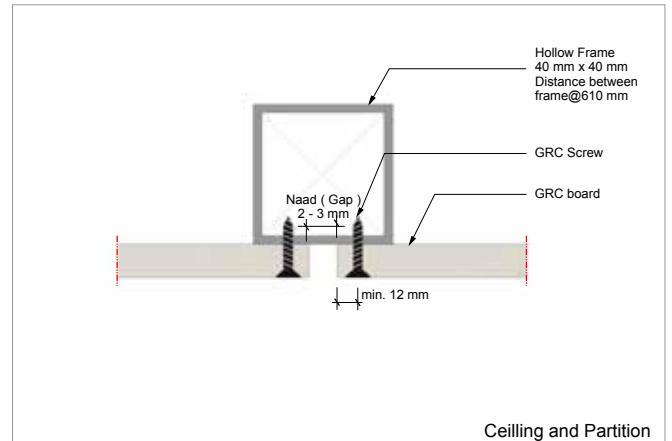

2. Flush Joint Application.

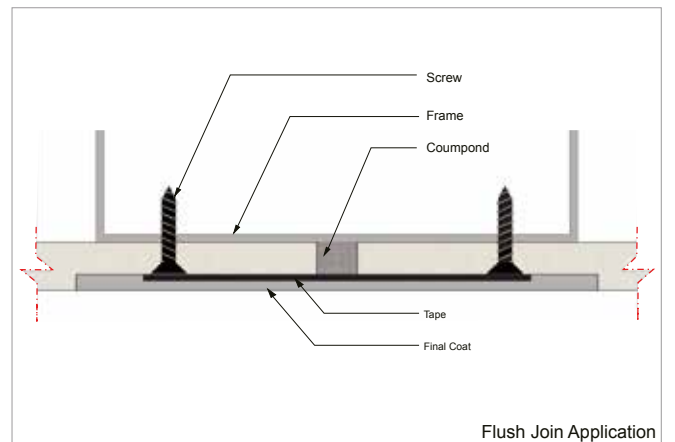

### B. The Distance of Frame and Board Application

1. We recommend to provide the distance between frames is 610 x1220 mm for ceiling application.

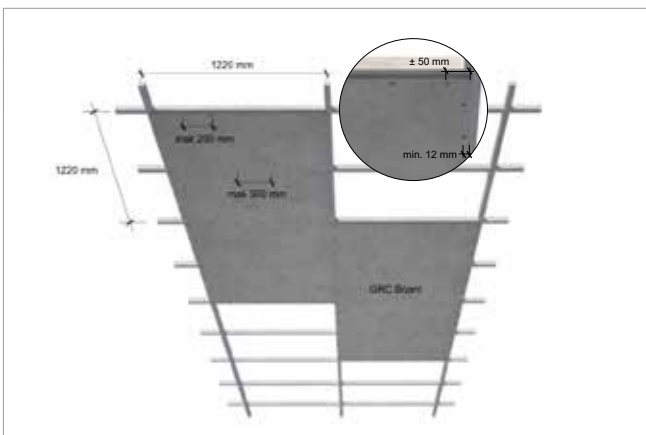

### 3. Lay-in Ceiling Application.



The Application of the side list on Ceiling

For the Application of the side list on GRC board ceiling, it has to be fastened by nails or screws.

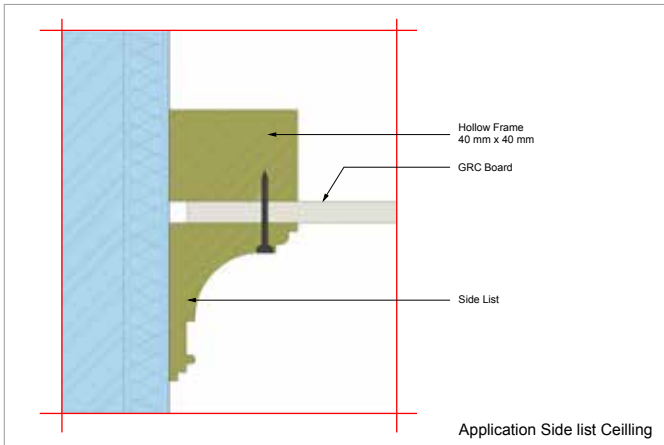

## IV. PARTITION APPLICATION

### A. Type and size of frames

Frame Types:

- Wood 50/70 mm
- Hollow Frame (minimum Thickness 0.4 mm)
- Metal Frame (minimum thickness 0.4 mm)

### B. Partition Finishing

The Application of board

GRC board can be applied as partition and can be finished by paint, wallpaper and ceramic tile.

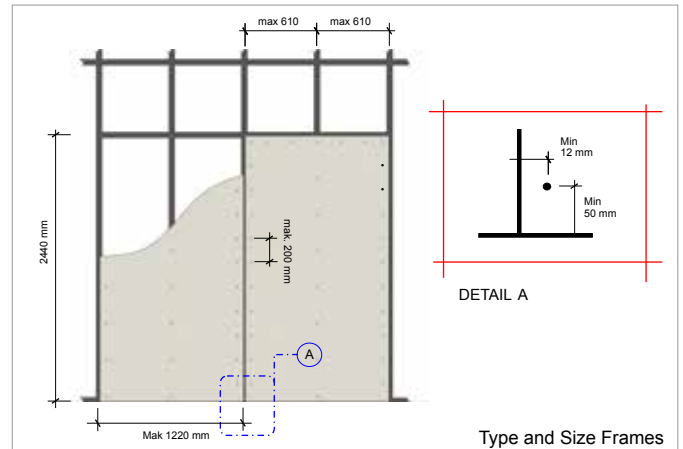

## V. FLUSH JOINT SYSTEM ON INTERNAL APPLICATION

The most important thing on GRC board application is to prevent the crack on the joints which is usually on the fiber cement board. GRC board has the right solution to prevent that problem by following the procedure of the application.

### A. Important things to note before applying flush joint system:

1. Ensure that the boards to be applied are dry.

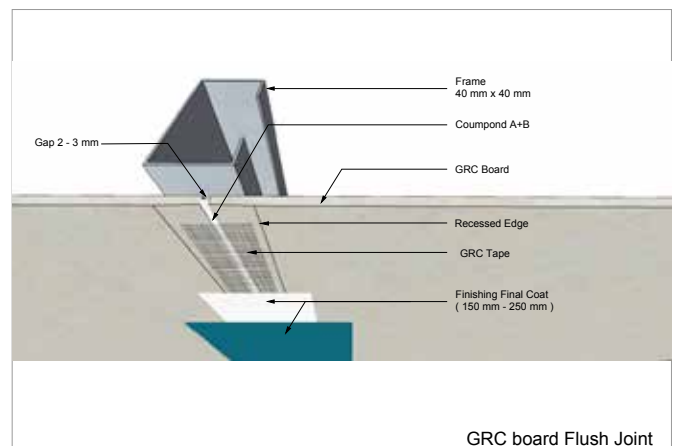

2. Allow gap about 2-3 mm between the edges of the boards.
3. The frames which are installed have to hold the edge of the boards. It is recommended to apply the boards that have recessed edge for flush joint system.

4. The distance and application of screws have to be correct.
5. Ensure that the material which is applied on joint application suits our recommendation:
  - a. GRC A + B is applied as a compound which fill into the gap between the boards.
  - b. GRC Tape as a cover of the joint
  - c. GRC PUTTY as the finishing of the joint

### B. The Procedure of Flush Joint application

1. First Step (GRC A+B compound and GRC tape)
  - a. Mix the compound GRC A+B sufficiently with ratio 1:1 and then stir it until it's mixed
  - b. Fill the gap between the boards with The GRC A+B compound using little spade.
  - c. After the gap was filled with the GRC A+B compound, place the GRC tape on the surface of the joint and then let the compound dried for minimal four hours.
2. Second Step (Applying GRC PUTTY)
  - a. After the first step is completely dry, apply GRC PUTTY compound to cover the surface of the joint.

- b. Then use sandpaper to get best result to smoothen the surface.

### 3. Expansion Joint

Expansion Joint is required for application in large area to prevent which usually happen because of the changing

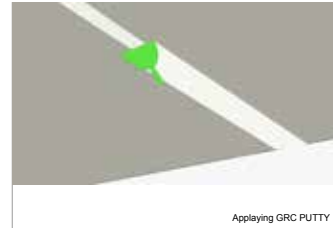

Applying GRC PUTTY

weather, high humidity or structural. Expansion joint for ceiling is applied on every  $\pm 70$  m<sup>2</sup> meters.

For expansion joint application, the gap between boards could be exposed, or covered by PU (polyetherane Sealant).

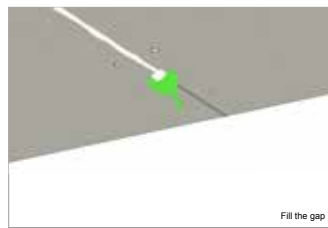
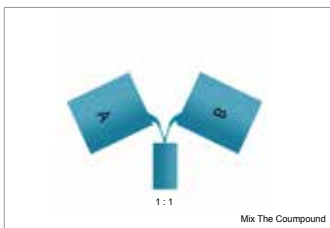
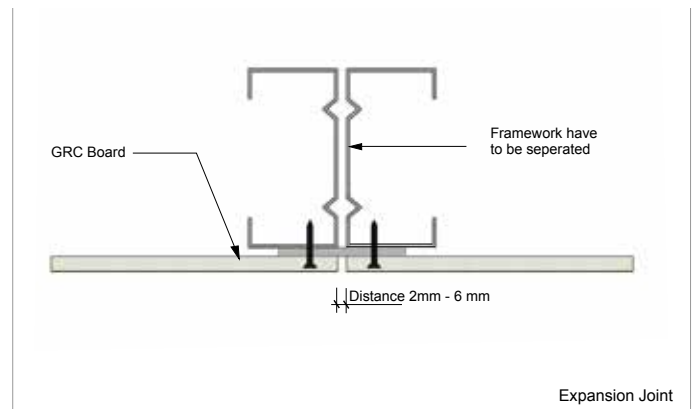

GRC Tape



**Fire Resistant**

# CLADDING SERIES



## GRC SUPERPANEL

### I. ADVANTAGES

GRC Superpanel is fiber cement board product which has GRC board higher level of durable compare to GRC board, so even the thickness of the board is relatively thin the character of the panel is more durable and more resistant to the weather.

### II. PRODUCT INFORMATION

#### A. Function

GRC Superpanel is very suitable and practical to be applied as exterior application to deal with extreme weather.

#### B. Size and Application

T x W x L (mm)	Weight (Kg)	Application
9 x 1220 x 2440	45.5	Cladding/Facade
12 x 1220 x 2440	62.6	

#### C. Cutting

For cutting the panel it is recommended to use circular saw or grinder which is equipped with blade that could cut stones.

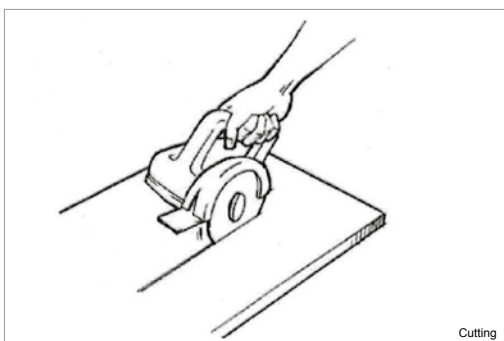

### D. Screws

#### 1. Screws.

For GRC Superpanel application which is sustained by metal framework could apply GRC Screw 9-15mm.

This Screw is design to have it's own bit drill (self-drill) so it could pierce and through the metal framework which has thickness 3 mm. If the frame applied is thicker, the framework has to be countersunk first by metal drill.

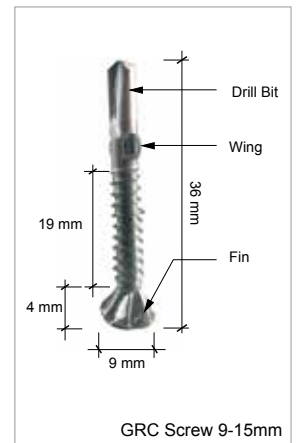

### III. CONSTRUCTION AND DETAIL OF APPLICATION

#### 1. Frameworks.

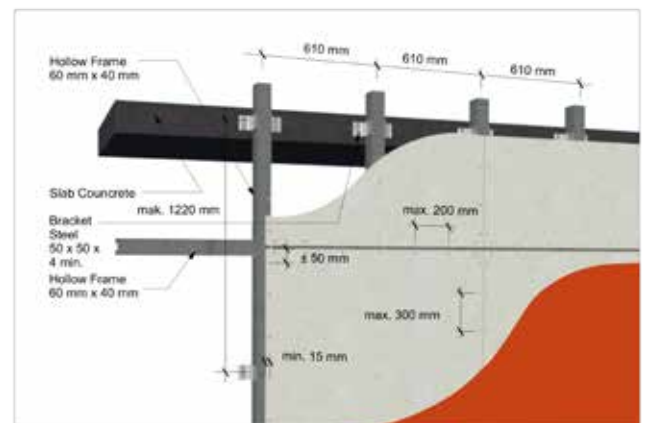

- Vertical frame that could be applied such as:
  1. Furring channel 75 x 45 x 1.6 mm.
  2. Hollow 60 x 40 x 1.6 mm (min).
  3. L plat 50 x 50 x 5 mm (min)
- Horizontal frame could apply metal frameworks CNP 75, 100 and 125.
- The maximum distance vertical frameworks is 610 mm.
- The maximum distance horizontal frameworks is 1220 mm



**Moisture Resistant**

## 2. Screw Position.

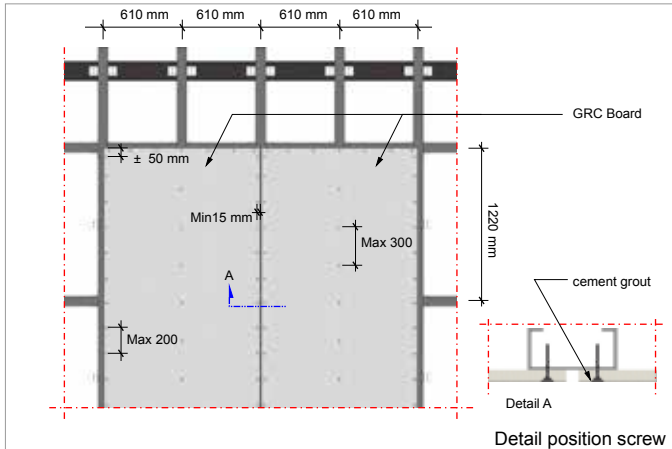

- The minimum distance between the screw and the corner of the GRC Superpanel is +/- 50 mm for width side and +/- 100 mm for length side, while the minimum distance between the screw and edge of GRC superpanel is 15 mm.
- The Maximum distance between screws on the outside of panel is 200 mm, while the maximum distance between screw on the middle of panel is 300 mm.
- GRC Screw 9-15mm is countersunk and covered by epoxy/cement grout to avoid corrosion.

## 3. Joint.

- Joint between GRC Superpanel could apply open Joint system or flexible joint (Applying sealent to get the best result. It is recommended to allow similar gap for each joints). It is recommended to allow gap about  $\pm 10$  mm between the panel on exterior application.
- For any joint that Flexible joint system, is recommended to apply sealent that contains of Polyurethane or sealent which has high elasticity, resistant to weather, high performance adhesive and paintable.

## 4. Finishing.

- For Finishing processed of GRC Superpanel water-base paint could be use

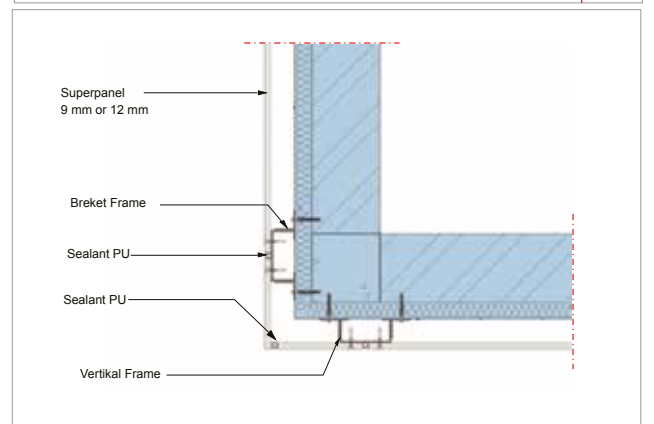
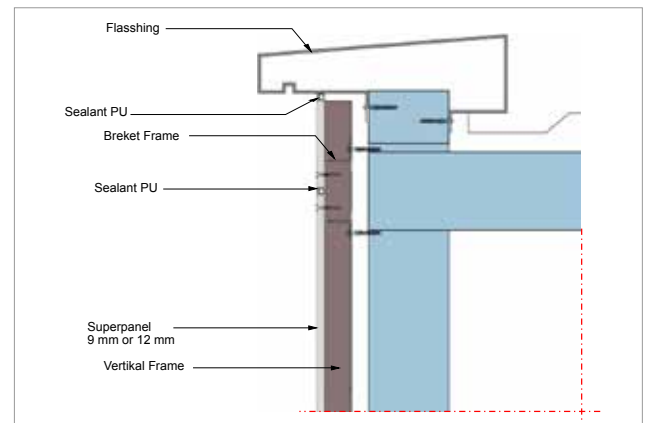
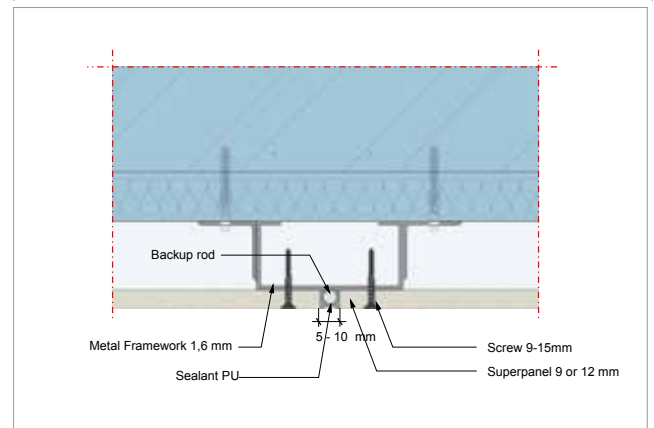
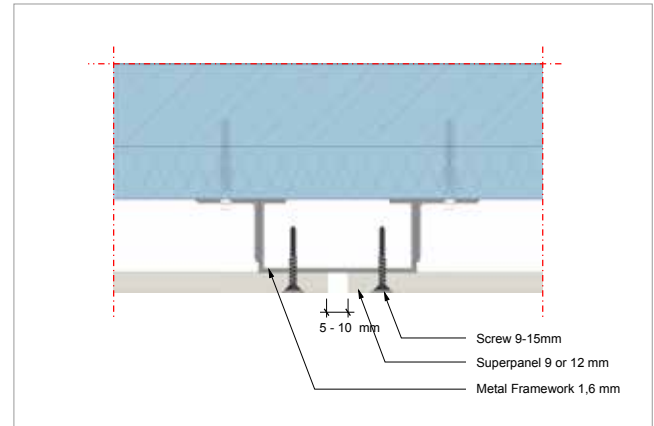

# PLANK AND PLINT SERIES



They have all of the advantages of GRC board product and also resistant to weather

## GRC SUPERPLANK, GRC SIMPLEPLANK, GRC TIMBERPLANK AND GRC MAHONI PLANK

### I. ADVANTAGES

GRC Superplank, GRC Simpleplank, GRC Timberplank and GRC Mahoni plank are the product of GRC board which is produce some variant sizes for exterior application as a plank or siding plank. They have all of the advantages of GRC board product and also resistant to weather, so it is able for exterior application.

### II. PRODUCT INFORMATION

#### A. Function

- GRC Superplank is a cement board plank that has profile on its edge, so it could beautify the buildings.
- GRC Simpleplank is a cement board plank that has square edge for minimalist and economical buildings.
- GRC Timberplank is a cement board plank that is designed of wood pattern on the surface, so it could present natural wood concept on the buildings.

**Termite Resistant**



- GRC Mahoni plank is a cement board plank that is designed to resemble flat wood and smoother materials, so it could be replace the wooden board material.

**B. Size and Application.**

- GRC Superplank

T x W x L (mm)	Weight (Kg)	Application
9 x 75 x 2440 BV1/BV2	2.8	Plint / Siding
9 x 100 x 2440 BV1/BV2	3.8	Listplank /Skirting / Siding
9 x 200 x 2440 BV1/BV2	7.5	Listplank / Siding
9 x 300 x 2440 BV1/BV2	11.3	

- GRC Simpleplank

T x W x L (mm)	Weight (Kg)	Application
8 x 100 x 2440	3.4	Listplank / Skirting / Siding
8 x 200 x 2440	6.7	Listplank / Siding
8 x 200 x 3000	8.4	
8 x 300 x 2440	10.1	
8 x 300 x 3000	12.7	

- GRC Timberplank

T x W x L (mm)	Weight (Kg)	Application
8 x 100 x 2440	3.1	Listplank / Skirting / Fence / Siding
8 x 200 x 2440	6.1	Listplank / Fence / Siding
8 x 200 x 3600	9	
8 x 200 x 4000	10	
8 x 300 x 2400	9.2	
8 x 300 x 3600	13.5	
8 x 300 x 4000	15	

- GRC Mahoni Plank

T x W x L (mm) SE	Weight (Kg)	Application
8 x 100 x 3000	4.2	Listplank / Skirting / Fence / Siding
8 x 200 x 3000	8.4	
8 x 300 x 3000	12.7	

**C. Cutting**

For cutting the panel it is recommended to use circular saw or grinder which is equipped with blade that could cut stones.

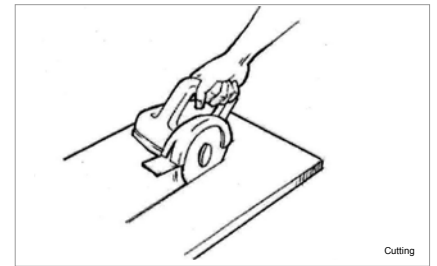

**D. Nail and Screw**

**1. Nail.**

For plank application which is sustained by wood framework could apply GRC nail. It has a better strength than a common nail, so it is very suitable for plank application.

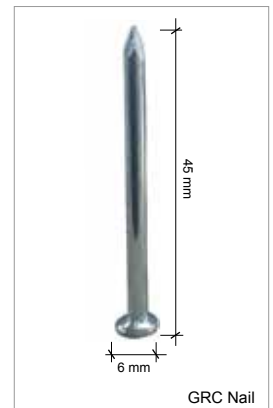

**2. Screws.**

For Plank application which is sustained by metal framework could apply GRC Screws for 9 – 15 mm

This Screw is design to have it's own bit drill (self-drill) so it could pierce and through the metal framework which has thickness 3 mm. If the frame applied is thicker, the framework has to be countersunk first by metal drill.



### III. APPLICATION DETAIL AND CONSTRUCTION

#### A. Plank

##### 1. Frame.

- Wood framework, wood 50/70 mm
- Light metal Framework
- Hollow Steel and CNP

##### 2. Screw Position.

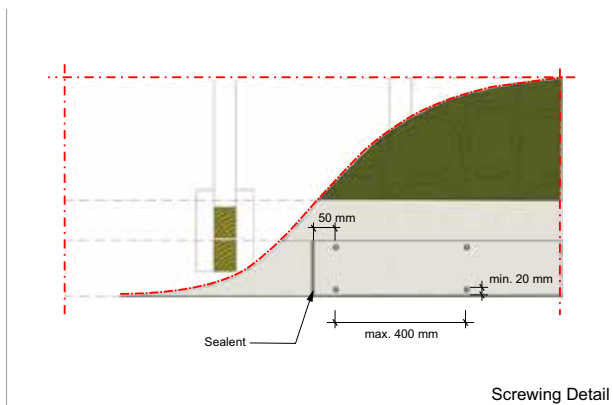

##### 3. Joint.

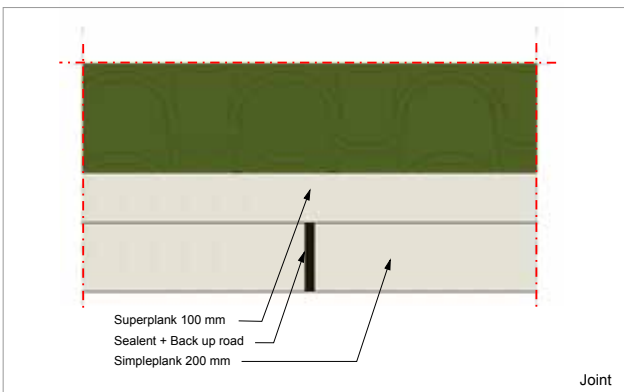

##### 4. Finishing.

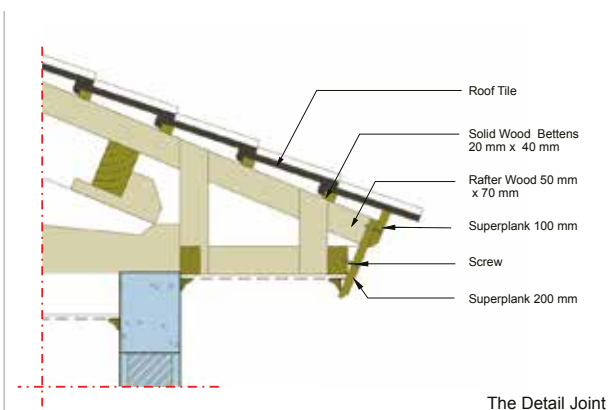

For Finishing process on the plank application of GRC board could apply water base and oil base paint, it is recommended to apply the paint which is resistant to weather. To emphasize the natural wood colour it is recommended to cover the plank with the polish.

#### B. Siding

##### 1. Frame.

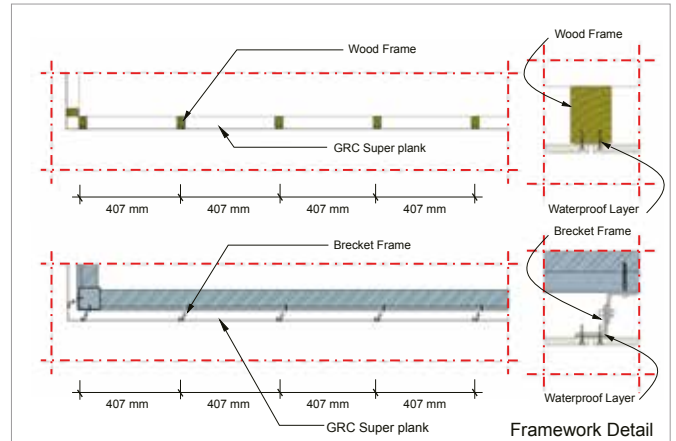

- Wood framework 50/70 mm
- Metal frameworks Thickness 1.2 mm
- The Distance between frames which is recommended is 407 mm

##### 2. Screw Position.

For this application, the minimum distance between screw and edge of the board is 20 mm (look at the picture).

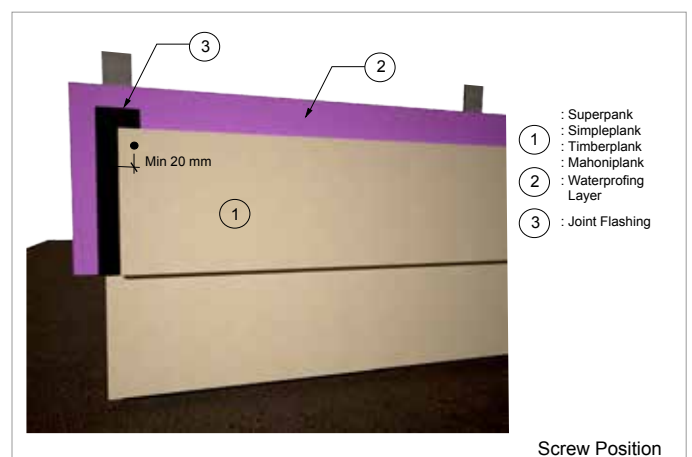

Fungi Resistant



### 3. Joint.

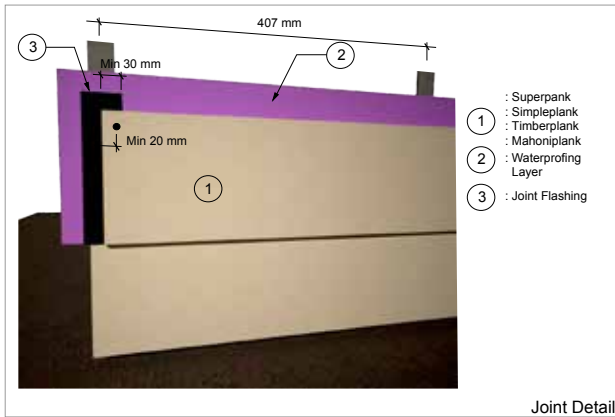

There are some techniques of joint on siding plank application:

- Sealant which contains of polyurethane
- The joint is fastened by joint flashing (look at the picture)
- Or the width of the joint flashing that is recommended is 60 mm.

### 4. Finishing.

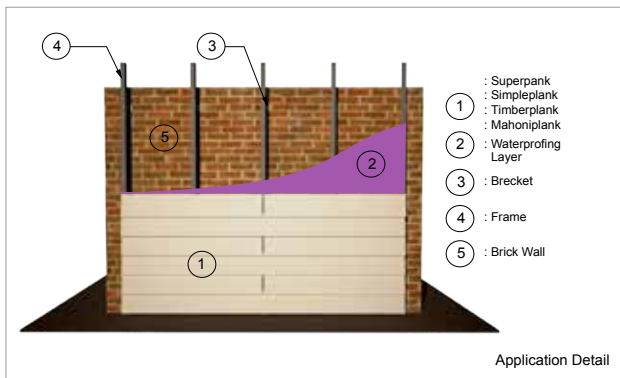

For Finishing on siding plank application could apply water base or oil base paint. Because it is an external application, so it is recommended to apply the paint which is resistant to the weather. To emphasize the colour of the wood for timberplank application, you could apply polish.

### Detail of siding plank installation

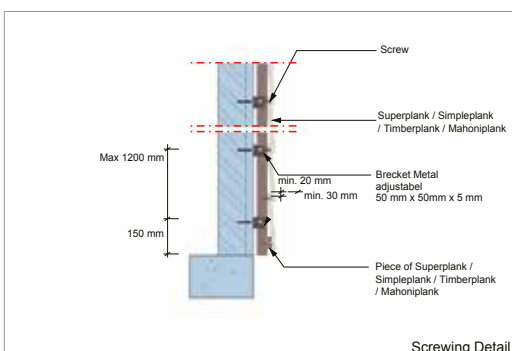

### C. Skirting

#### 1. Screws Position

For this application, the minimum distance between screw and edge of the board is +/- 20 mm and distance between screw is max 300 mm.

#### 2. Jointing

joint on skirting application is using PU sealant.

#### 3. Finishing

For Finishing on skirting application could apply water base paint.

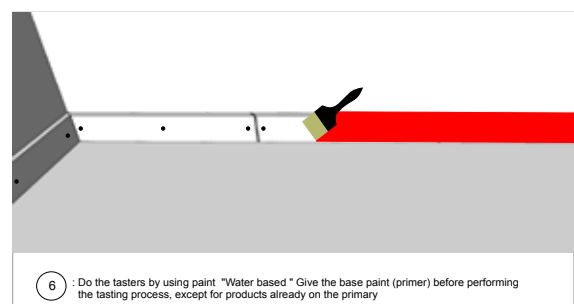
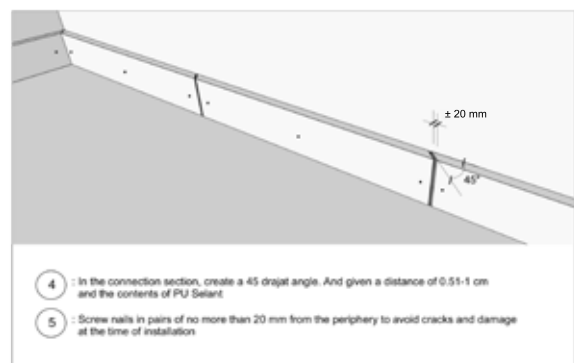
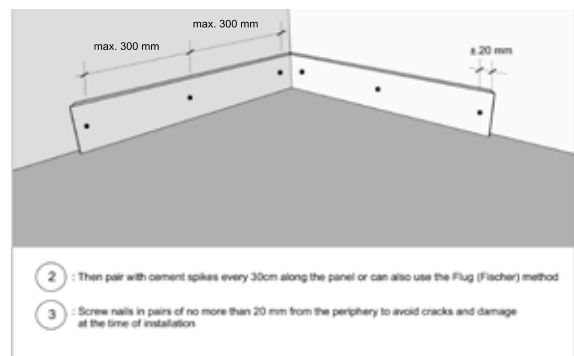
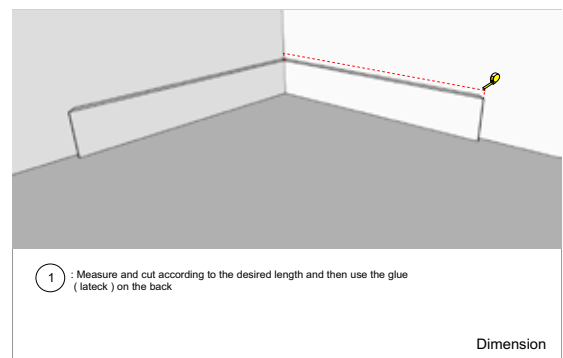

# FLOOR SERIES



## GRC SUPERPANEL

### I. ADVANTAGES

GRC Superpanel is one of the GRC products that can be applied to floors with recessed on both sides and smooth surface. The thickness of board is 15 and 20 mm so it is strong and safe to use on the floor.

### II. PRODUCT INFORMATION

#### A. Function

GRC Superpanel is suitable and practical to be applied as exterior or interior in order to add to the aesthetic value of a building.

#### B. Size and Application

T x W x L (mm) SE	Weight (Kg)	Application
15 x 1220 x 2440	78.4	Floor
20 x 1220 x 2440	104.7	

#### C. Cutting

For cutting the panel it is recommended to use circular saw or grinder which is equipped with blade that could cut stones.

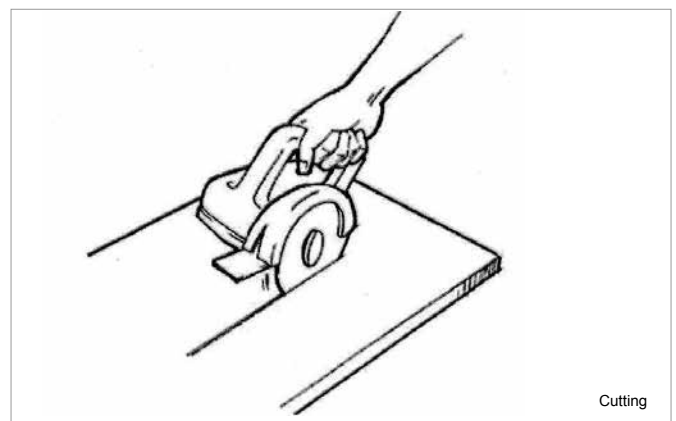

## D. Screw

### 1. Screws

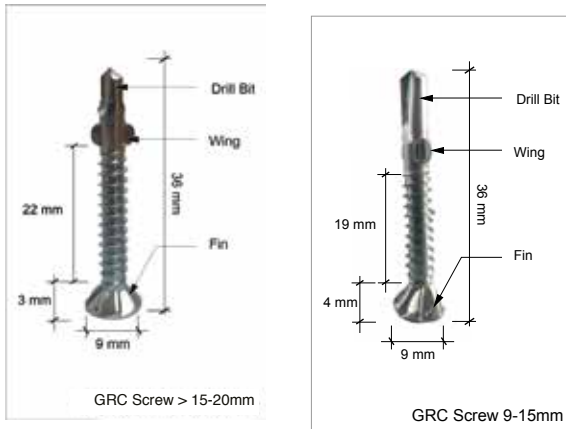

For GRC Superpanel application which is sustained by metal framework could apply GRC Screws for >15 – 20 mm.

This Screw is design to have it's own bit drill (self-drill) so it could pierce and through the metal framework which has thickness 3 mm. If the frame applied is thicker, the framework has to be countersunk first by metal drill.

## III. CONSTRUCTION AND DETAIL OF APPLICATION

### 1. Frame

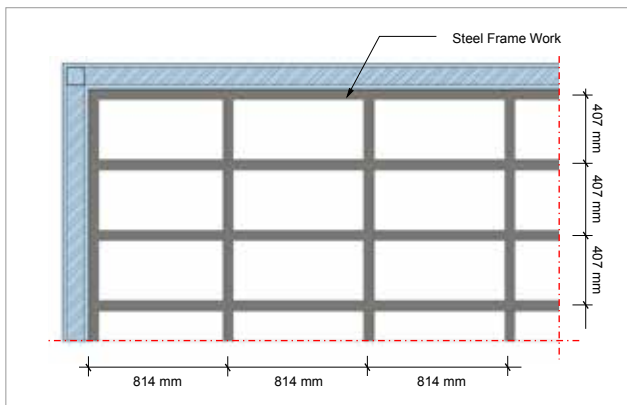

- Light metal Framework , thickness min 2.3 mm.
- Hollow Steel and CNP, thickness min 2.3 mm.
- The installation of frame which is recommended is maximum 407 x 814 mm for 15 mm thickness and maximum 610 x 1220 mm for 20 mm thickness.

### 2. Screw Position

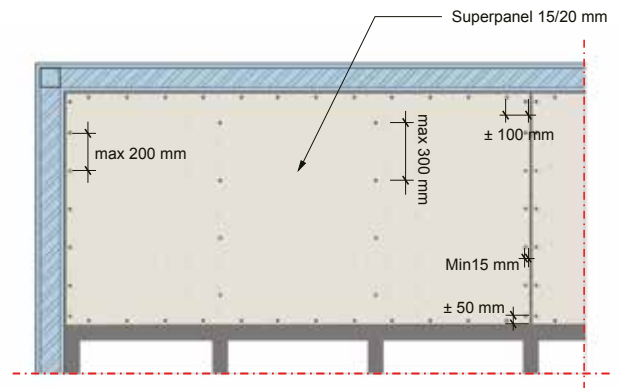

### 3. Jointing

Jointing application on the floor is more flexible, and not required compound on the gap between the panel. It depends on which kind of finishing that is needed. It is recommended to apply sealant which contains PU (polyurethane).

### 4. Finishing

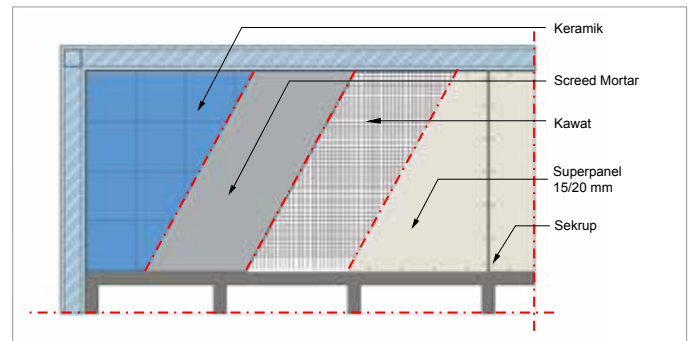

**Sound Insulation**



GRC Mahoni Deck is product of GRC board with wood surface so that the floor feels and looks like wood.

## GRC MAHONI DECK AND GRC SUPER DECK

### I. ADVANTAGES

- **GRC Mahoni Deck** is product of GRC board with wood surface so that the floor feels and looks like wood.
- **GRC Super Deck** is product of GRC board with camber edges on both sides with a smooth surface.

### II. PRODUCT INFORMATION

#### A. Function

Both of these products have the same function as a deck and to beautify a building, depending on the choices and needs of consumers.

#### B. Size and Application

T x W x L (mm) CE2	Weight (Kg)*	Application
20 x 100 x 2400	8.2	Decking
20 x 200 x 2400	16.4	
20 x 300 x 2400	24.6	

\*approximately

### C. Cutting

For cutting the panel it is recommended to use circular saw or grinder which is equipped with blade that could

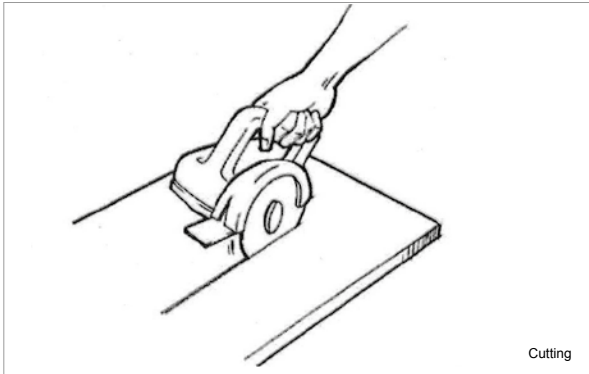

cut stones.

### D. Screws



#### 1. Screws

For GRC Deck Series application which is sustained by metal framework could apply GRC Screws for >15 – 20 mm.

This Screw is design to have it's own bit drill (self-drill) so it could pierce and through the metal framework which has thickness 3 mm. If the frame applied is thicker, the framework has to be

countersunk first by metal drill

## III. CONSTRUCTION AND DETAIL OF APPLICATION

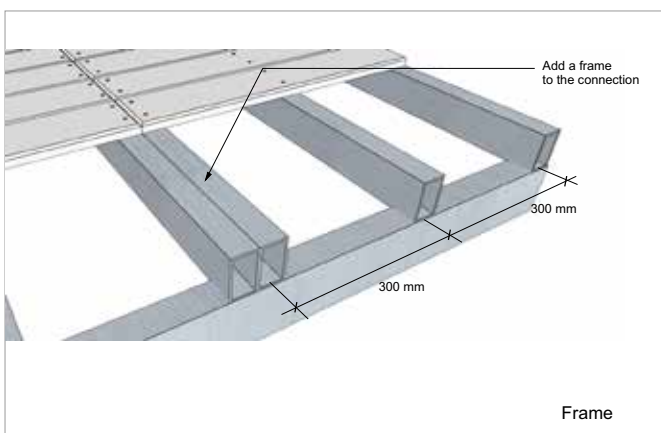

### A. Frameworks:

- Metal frame CNP 100-125, Thickness 2-3 mm
- The installation of support frame which is recommended is maximum 300 mm.

### B. Position of the Screws

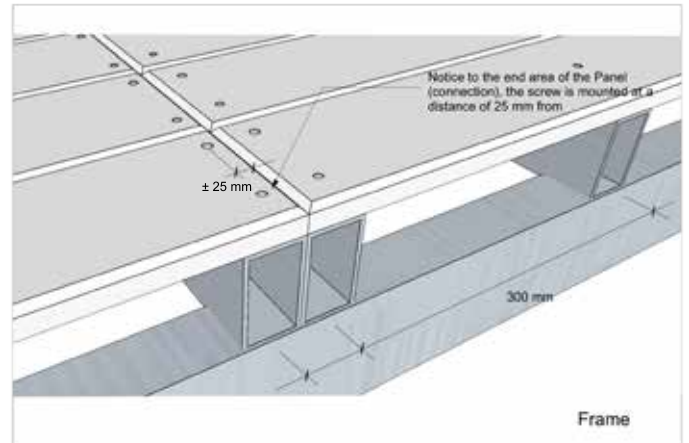

### C. Finishing

For finishing on Deck application could apply wood paint for fiber cement board.

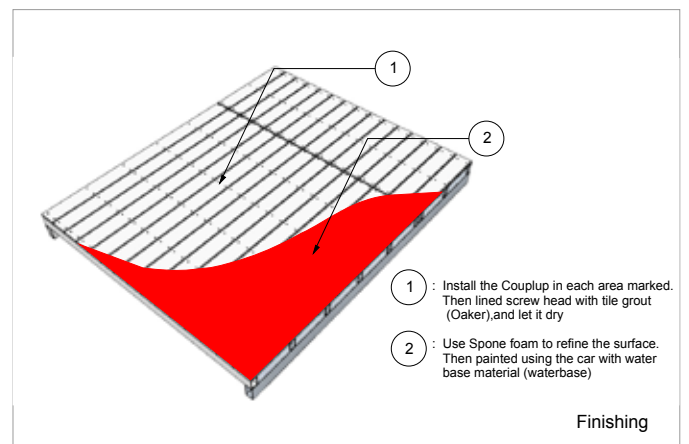

**Strong & Durable**

## DECORATIVES SERIES





The GRC Decoratives Series is a cement board product from GRC board that can be applied outdoors and indoors

## I. ADVANTAGES

The GRC Decoratives Series is a cement board product from GRC board that can be applied outdoors and indoors and functions as a building decoration to make it look more beautiful.

In addition to the designs and sizes that are already available, consumers can order with a customized design as well as the desired size and thickness.

## II. PRODUCT INFORMATION

### A. Function

- **GRC Decoplank** is used for listplank applications to add to the aesthetic value of buildings and further emphasize ethnicity.
- **GRC Deco panel Motive** is an innovative product from GRC board that can be used for various applications such as: partition, ceiling, walls etc.
- **GRC Deco panel Brick** is a GRC board product with a surface in the form of a checkered pattern resembling an exposed brick that can be applied to walls, partitions and ceilings.
- **GRC Deco panel Line** is a GRC board product with a straight line channel surface that can be applied to walls, partitions and ceilings.



Easy Application

## B. Size and Application

### 1. Decoplank

T x W x L (mm)	Weight (Kg)*	Application
9 x 200 x 1200	2.5	Listplank
9 x 300 x 1200	3	

\*approximately

### 2. Decopanel Motive

Thickness (mm)	Width (mm)	Length (mm)	Application
6-20	Max 1200	Max 2400	Wall, Partition, Sketsel, Ceiling, etc

### 3. Decopanel Line

Thickness (mm)	Width (mm)	Length (mm)	Application
9-10	Max 1200	Max 2400	Wall, Partition, Sketsel, Ceiling, etc

### 4. Decopanel Brick

Thickness (mm)	Width (mm)	Length (mm)	Application
9-10	Max 1200	Max 2400	Wall, Partition, Sketsel, Ceiling, etc

\*Available to customize design and dimension with condition apply

## C. Cutting

Specifically for decopanel motifs are advised to order the appropriate size so that it is no longer necessary to cut. It is not advisable to cut yourself to avoid damage to the material unless it has been consulted with the experts first.

For cutting another GRC Decorative it is recommended to use circular saw or grinder which is equipped with blade that could cut stones.

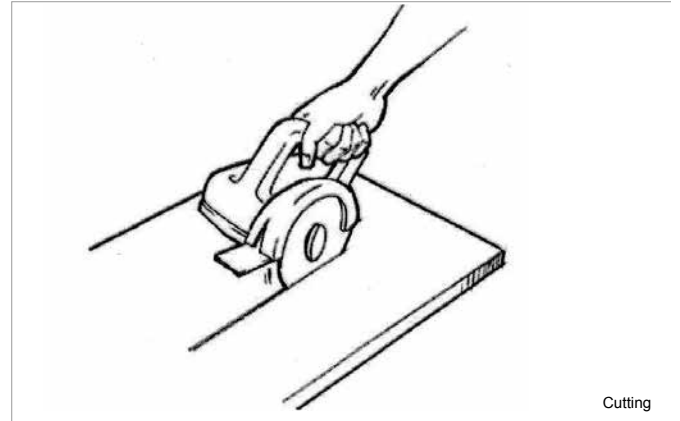

## D. Screws

### 1. Screws

For the application which is sustained by metal framework could apply GRC Screws depends on the thickness of board.

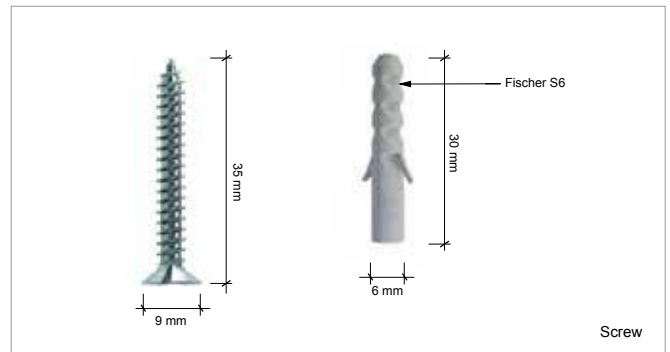



### III. CONSTRUCTION AND DETAIL OF APPLICATION

#### A. Frames

GRC board could also be applied on metal frame such as: galvanized steel, metal furring, and another type of metal frame which has thickness 0.4 mm – 1.2 mm.

The right method of frame installation is crucial in supporting the result of GRC board application.

#### B. Screws Position

The minimum distance between nails or screws with the corner of GRC board is 50 mm.

The minimum distance between nails or screws with the edge of GRC board is 12 mm.

The Maximum distance between nails and screws is not more than 200 mm (on the side of board).

#### C. Jointing

For Interior Application, can use flush joint system.

For Exterior Application, joint between Decoratives panel could apply open Joint system or flexible joint (Applying sealent to get the best result. It is recommended to allow similar gap for each joints). It is recommended to allow gap about  $\pm 10$  mm between the panel on exterior application.

For any joint that Flexible joint system, is recommended to apply sealent that contains of Polyurethane or sealent which has high elasticity, resistant to wheather, high performance adhesive and paintable.

#### D. Finishing

For Finishing on decoratives panel could apply with water base paint.

### PRODUCT TECHNICAL DATA FORM

Property Items	Value of Test	Standard
Tolerance of Thickness:		
$\leq 10$ mm	$\pm 0.5$ mm	ISO 8336 ; 2009
$> 10$ mm	$\pm 5\%$	ISO 8336 ; 2009
Tolerance of Length	+ 0 ; -2 mm	ISO 8336 ; 2009
Tolerance of Width	+ 0 ; -2 mm	ISO 8336 ; 2009
Tolerance of Square-ness	$\leq 3$ mm	ISO 8336 ; 2009
Tolerance of Straightness	$\leq 1.5$ mm	ISO 8336 ; 2009
Density	1.55 gr/cm <sup>3</sup>	ISO 8336 ; 2009
Modulus of Rupture	180 kg/cm <sup>2</sup>	ISO 8336 ; 2009
Water Absorption	23%	ASTM C1186
Water Conten	6-9 %	ASTM C1186
Non combustible	Pass	BS 476 Part 4 :1970

Smooth Surface



# ACCESSORIES SERIES



GRC nail is suitable to be applied on ceiling and partition which is fixed on by wood frame

To get the maximum result of GRC board application, we provides accessories to support GRC board application, such as:

## 1. GRC Nail

GRC nail is suitable to be applied on ceiling and partition which is fixed on by wood frame. GRC Nail is design in such a way that it is equipped with the bigger and thinner head, so it's easy to be countersunk.

The GRC nail is provide in two types, galvanized (rust proof) and non galvanized.

## 2. Screw

To fasten GRC board on metal frame such as Hollow, metal furring and metal stud GRC screw has four types:

### A. GRC Screw 4mm

This screw is made for the application of GRC board 4 mm. This screw is equipped by a thinner head and single thread, so it's very suitable for GRC board 4 mm application.

### B. GRC Screw $\geq 5 - 8$ mm

This screws is applied on GRC board 5 mm for 8 mm. And not recommended for the board which has

thickness 4 mm. This GRC Screw has a head equipped with fins and double thread, so it's easier to be countersunk when it's applied.

### C. GRC Screw 9 – 15 mm

This screw is applied on all product who has thickness 9 – 15 mm

### D. GRC Screw $\geq 15 - 20$ mm

This screw is applied on all product who has thickness  $>15 - 20$  mm

## 3. GRC A+B Compound

This Compound is used to fill the gap between the joints of the GRC board.

## 4. GRC Tape

The function of GRC Tape is to cover and strengthen the join, also for intermediary between surface of GRC A+B compound and GRC PUTTY.

## 5. GRC PUTTY

GRC PUTTY is applied as cover on the surface of joint and the hole of screw to make a smooth surface.

# PRODUCT GUARANTEE

We Guarantee that our products are sold in good condition without damage or faulty production or it's raw materials. This product warranty does not cover damage caused by:

1. Transportation and it's agent sending the goods to the customers as it is out of the company's control.
2. Installation quality and system of workers as various factors affect good and right installation system.
3. Suitability of our product on particular application which are not according to our recommendations.

# GRC board

**THE FINEST CHOICE IN FIBRE CEMENT BOARD**

Manufactured by :

PT. BANGUNPERKASA ADHITAMASENTRA



GRAHA GRC board  
Jl. S. Parman Kav. 64 Jakarta CA 11410  
Indonesia



Phone : (+62) 21 53 666 800 ( hunting )  
Whatsapp : (+62) 856 2480 5662  
Fax : (+62) 21 53 666 720



Email : [marketing@grcboard.com](mailto:marketing@grcboard.com)  
Web : [www.grcboard.com](http://www.grcboard.com)